

Cast Steel (WCB) 'Y' Type Strainer

ASA 300#



TECHNICAL DATA

Manufacturing Std	As per Manufacturing
Testing & Inspection Std	API 598
Face To Face	As Per ASA300#
End Connections	Flanged As Per ASA300#



No.	Nomenclature	Material
1	Body	C.S. (ASTM A 216 Gr. WCB)
2	Stud & Nut	M.S. IS - 1367
3	Mesh	SS 304
4	Cover	WCB/MS
5	Gasket	SS304 Spiral Wound Metallic Gasket

SIZE		L	T	K	D	N	J	R
INCH	MM	F TO F	F.T.	PCD	O.D.	No. of Hole	Hole Dia.	R/F
1"	25	203	18	89	125	04	16	51
1 1/2"	40	229	21	114	155	04	16	73
2"	50	267	24	127	165	08	19	92
2 1/2"	65	292	27	149	190	08	22	105
3"	80	318	30	168	210	08	22	127
4"	100	356	32	200	254	08	22	157
5"	125	400	35	235	280	08	22	186
6"	150	445	36.5	270	320	12	22	216
8"	200	559	41.3	330	380	12	25	270

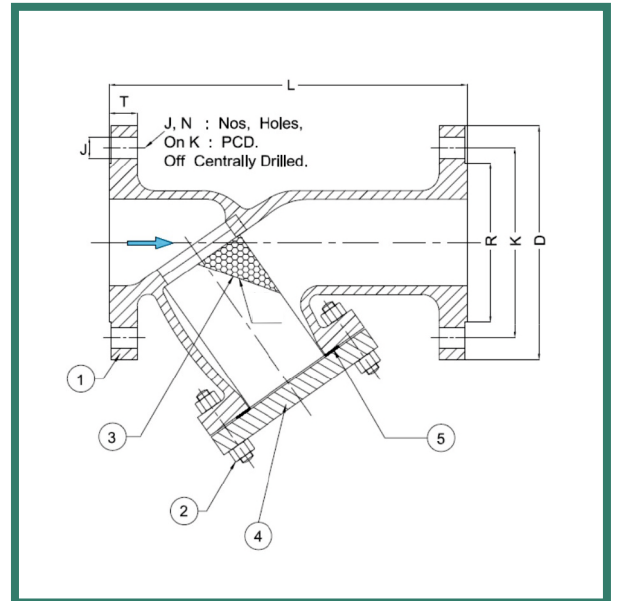

*All Dimensions are in mm.

SERVICE RATING & TEST PRESSURE

Class	Working Pressure	Temperature Maximum	Hydraulic Test Pressure	
			Body	Seat
ASA300#	20Kg/cm ²	400° C	73kg/cm ²	-

Manufactured By:

VALSON VALVES MFG. CO. AHMEDABAD (GUJ)

www.valsonvalves.com